

Citia™ Silver BOS Stair Lift

Unit Dimensional Drawing

SPECIFICATIONS

- Rated Load:** 375 pounds (170kg)
- Speed:** 19 fpm (.10 ms)
- Travel:** 32' max. (9.75 m) (track length)
- Power Supply:** 115 VAC, 60 Hz, 3-wire grounded outlet
- Incline limits:** 25° to 45° (and up to 55° with local jurisdiction approval)
- ETL and cETL Listed**

STANDARD EQUIPMENT

- Drive System:** Rack and pinion
- Motor:** 1/2 hp, 24 VDC (reversible)
- Control System:** Battery Operated System (BOS) with SoftStart / SoftStop control board with diagnostic LED's with two 12-volt maintenance free batteries.
- Controls:** Constant pressure handheld pendant control and 2 wireless remote controls (infra-red)
- Charging Stations:** Integrated charge stations at top and bottom, charge fault alarm, low battery indication through audible alarm, reduced speed and LED indication
- Brake:** Self-locking worm gear
- Track:** 5 1/2" wide extruded aluminum
- Track Length:** 16' stock or custom cut
- Track Finish:** Unfinished aluminum
- Unit Finish:** Ivory white powder coat finish
- Upholstery:** Oatmeal herringbone fabric; taupe or misty gray vinyl over padded seat and seat back
- Seat:** 21" (533mm) wide seat with two fixed arms, folding seat, seat belt, and 70° locking swivel seat at top and bottom landing
- Safety Devices:**
 - Footrest obstruction sensors
 - Swivel seat cut-off switch
 - Final limit switches
 - Seat belt
- Warranty:** Five years on drive train and two years on all component parts

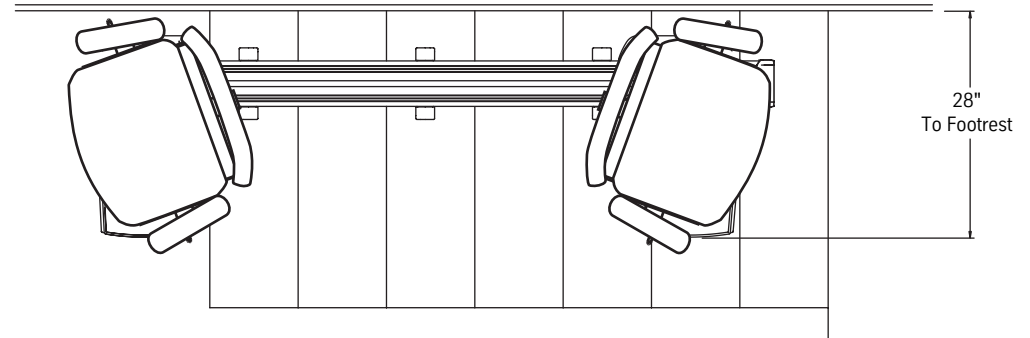

TOP VIEW

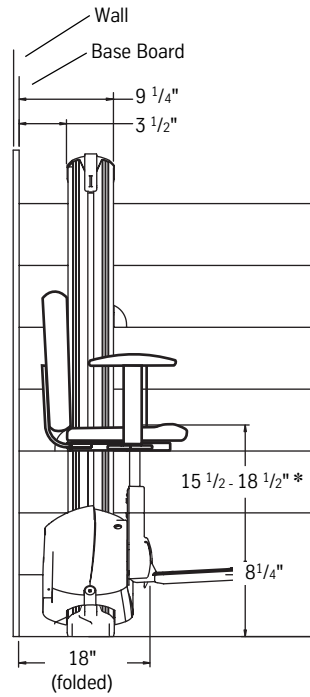

END VIEW

*Dimensions are based on a 35° stair angle and standard seat heights with a 3 1/4" top track extension. The seat height at the lower landing can be adjusted by the dealer to heights between 23 1/2" - 26 1/2". See Measurement Sheet - Order Form for details on calculating the track extension based on desired seat heights at the top and lower landings.

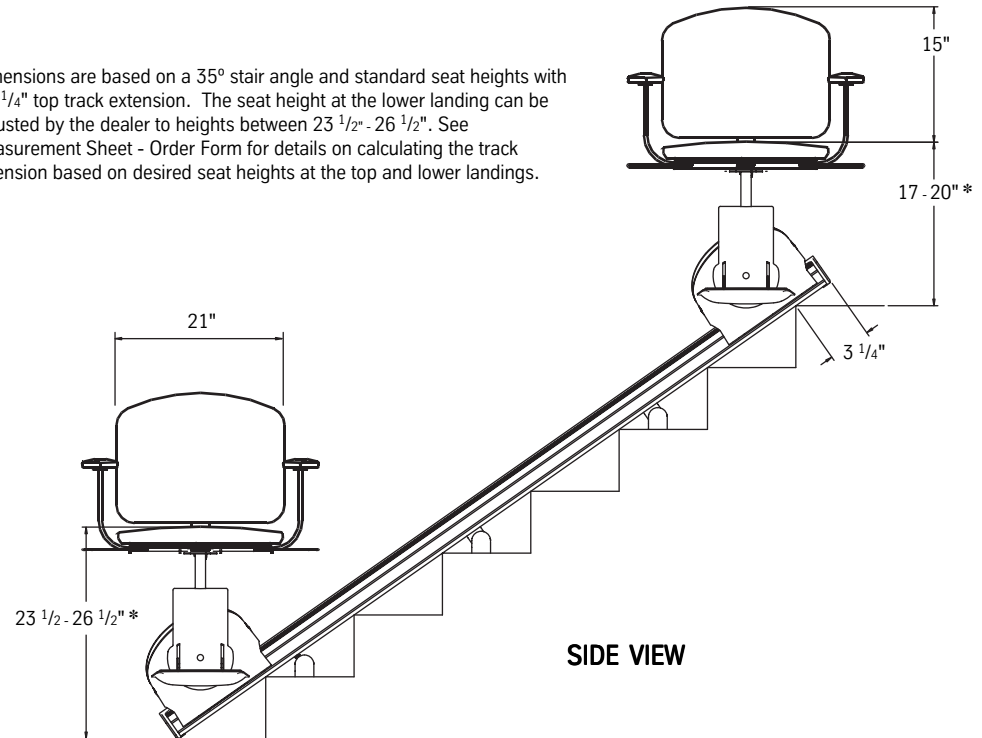

SIDE VIEW

ThyssenKrupp Access
Accessibility Division



ThyssenKrupp